

**ECO
FRIENDLY**



BLUEDRY



BLUEDRY USER MANUAL
Model HD-BD988



BLUEDRY - HIGH SPEED HAND DRYER

PLEASE CAREFULLY READ THROUGH THIS MANUAL BEFORE USING THE PRODUCT. OBSERVING ALL SAFETY INFORMATION, WARNINGS AND CAUTIONS WILL PROTECT YOURSELF AND OTHERS. PLEASE KEEP INSTRUCTIONS FOR FUTURE REFERENCE.

1. TECHNICAL SPECIFICATIONS

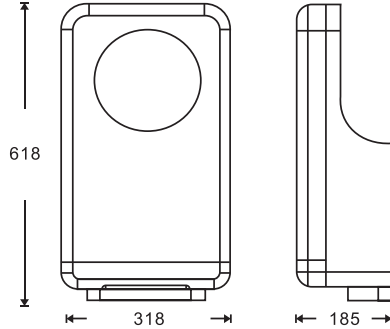

ITEM CATEGORY	PERFORMANCE DATA
Operating Voltage	220-240Vac, 50/60Hz, 5.0-8.0A, 500-1450W
Airspeed	90-135M/S, Adjustable
Air Output Temperature	35-40°C (113°F) - Ambient Temp. 20°C (68° F)
Dryer Shell Deliver	89-124 m ³ /h (55-76 CFM)
Cover Type	ABS - Antibacterial coated
Motor Type	Brushed: 900W 11000-22000 R.P.M.
Heater Element	ON/OFF, 0-550W intelligent heating
Standby Power	3W
LED Colour	Standby colour blue
Drying Time	5-10 seconds
Circuit Operation	Infrared Automatic, self adjusting
Sensor Range	Standard 12cm±1cm (4-23/32")
Decibel Rating	MIN 65 dB-A to 78 dB-A MAX @ 1m
Timing Protection	25 seconds auto shut off
Drip proof	IPX4
Isolation	CLASS 1
Net Weight	8KGS
Shipping Weight	9.3KGS
Unit Size	318mm(W) X 618mm(H) x 185mm(D)

BLUEDRY - HIGH SPEED HAND DRYER

2. RECOMMENDED MOUNTING HEIGHTS

	A From main air outlet above finished floor (AFF)	B From datum point above (AFF)	C From bottom edge of dryer Above (AFF)
Men	1150mm (45-1/2")	710mm (27-61/64")	622mm (24-31/64")
Women	1080mm (42-1/2")	640mm (25-13/64")	552mm (21-47/64")
Children 4-7 years	780mm (30-1/2")	340mm (13-25/64")	252mm (9-59/64")
Children 8-10 years	880mm (34-1/2")	440mm (17-21/64")	352mm (13-55/64")
Children 11-13 years	965mm (38-1/2")	525mm (20-43/64")	437mm (17-13/64")
Children 14-16 years	1080mm (42-1/2")	640mm (25-13/64")	552mm (21-47/64")
Disabled	900mm (35-1/2")	460mm (18-7/64")	372mm (14-41/64")

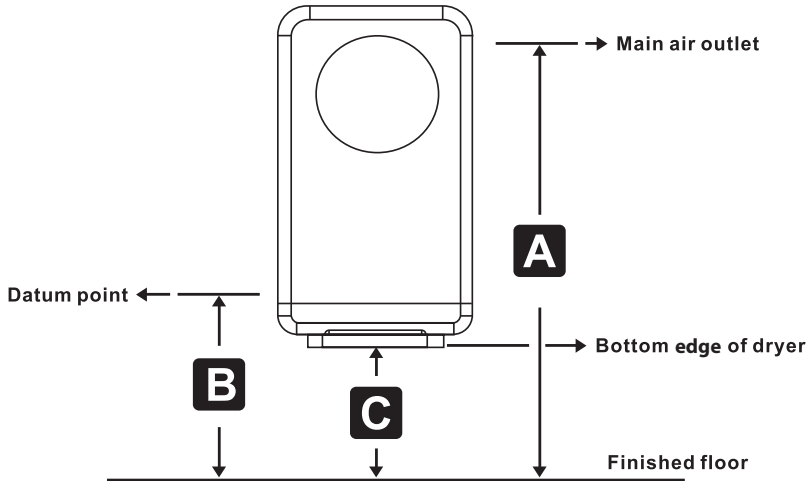

3. SOCKET OUTLET LOCATION

The dryer is supplied with a power cord. The power cord hole's position is on the bottom right of the dryer. The length of the cable is 1.5M. The cable will reach to the right side within a distance of 55cm and the left side within a distance of 45cm. We recommend a tail or connection plate from the fused spur is installed at this point in order to hide all cabling.

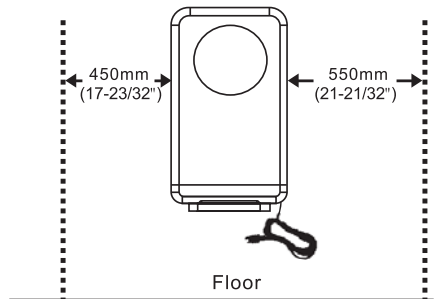

4. GENERAL SAFETY INFORMATION

WARNING - This product is intended for installation by a qualified service person. Use eligible solid conductor for wiring (1.5mm² for 220-240V).

WARNING - Disconnect power at the service breaker before installing or servicing.

WARNING - All units must be supplied with a 3-wire service. The ground wire must be connected to the dryer's backplate.

DANGER - Failure to properly ground unit could result in severe electrical shock.

5. INSTALLATION STEPS

1. Tape the installation template to the appropriate location on the mounting surface. Drill eight (8) holes at marked locations.(fig. 1).
2. Remove template and insert eight (8) plastic anchors (supplied) into drilled holes (fig.2).
3. Insert eight (8) screws (supplied) to fix backplate into top plastic anchors (fig.3).
4. Hang the dryer on the base plate (fig. 4).
5. Use key (supplied) to unlock and withdraw drawer. Screw (supplied) through the holes at backplate bottom. Insert the drawer back and lock the security screw (fig.5).
6. Connect power and stand by.

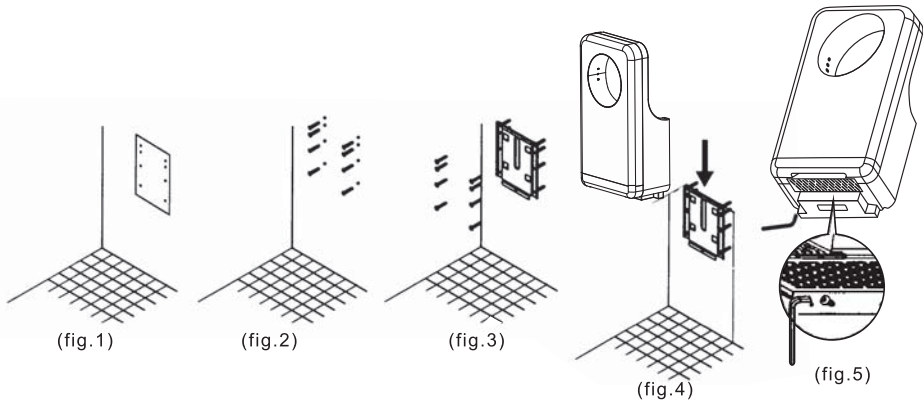

6. OPERATION

- Place your hands through the opening.
- Rub your hands together in the air flow.
- Remove hands and dryer will stop automatically.

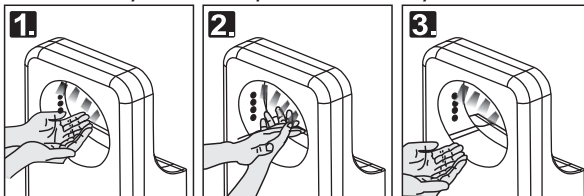

5. CLEANING AND MAINTENANCE

Periodic cleaning of the unit is recommended to ensure optimum performance.

- Wipe the cover with a damp cloth and mild cleaning solution.
- Do not Soak.
- Never use abrasives to clean the cover.

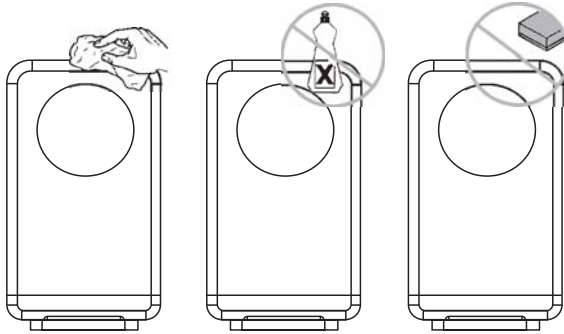

6. CIRCUIT DIAGRAM

Hand dryer (brush motor) control electrical circuit schematic:

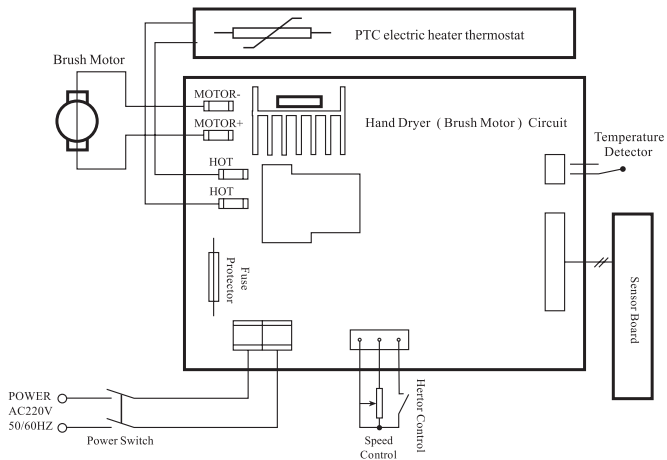

7. AIR SPEED ADJUSTMENT

The dryer noise level can be varied by adjusting the motor speed. However, when lowering the motor speed, the drying time will increase also. The ability of this function will be dependent on the needs of the user. The factory setting for dryer's motor speed will be set at its highest speed. See below for how to adjust the dryer speed:

1. Use the key (supplied) to unlock and withdraw drawer (fig.1).
2. Using a flat blade screwdriver, gently turn adjustment potentiometer shaft (fig.2) clock-wise [CW] to increase power to maximum (shaft will hard stop; DO NOT OVERTURN!). Turn tool gently CCW to reduce power as required (shaft will hard stop; DO NOT OVERTURN!). Note that at minimum power the unit may not start if low line Voltage condition exists.
3. Insert the drawer back and lock the security screw.

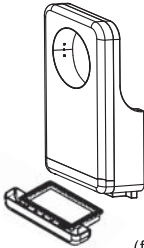

(fig.1)

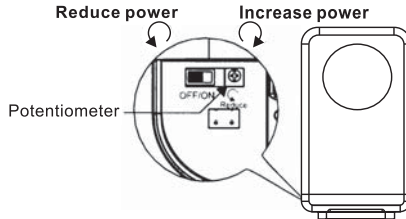

(Fig.2)

8. HEATER ELEMENT SWITCH ON/OFF

This dryer has been designed with a heater switch that can turn the heater ON/OFF. The heater switch does not affect the drying time. In cold weather conditions, it may be more comfortable if the heater is switched on when drying hands. However, it will save a third of the energy if it is turned off. This function can be adjusted depending on the needs of the owner. The factory setting for the heater will be on. See below for how to turn the heater ON/OFF.

NOTE: With the heater switch on, the heating element will automatically switch OFF when the ambient temperature exceeds 25 degrees and switch on when the ambient temperature drops below 24 degrees.

1. Use key (supplied) to unlock and withdraw draw (fig.1)
2. Switch it to the right to turn ON the heater. Switch it to the left to turn OFF the heater (see fig.2)
3. Insert the draw back and lock the security screw.

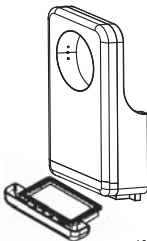

(fig.1)

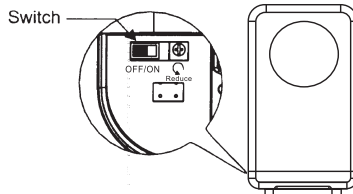

(fig.2)

9. HOW TO CHANGE THE SUPER FILTER & GEL BLOCKS

1. Use key (supplied) to unlock and withdraw drawer (fig.1).
2. Change the SUPER filter (fig.2).
3. Insert the drawer back and lock with the security screw.

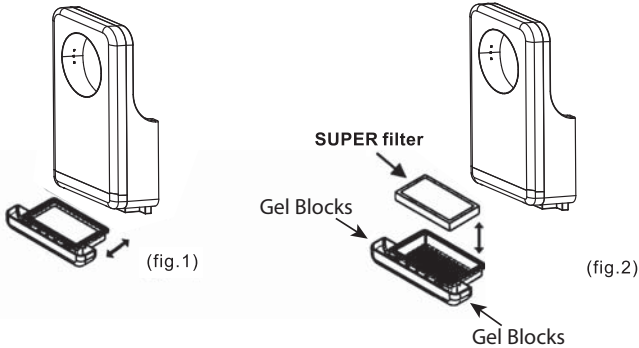

10. RECOMMENDED PERIOD FOR CHANGING FILTER & GEL BLOCKS

SUPER Filter-

In general use it's recommended to change the SUPER filter six (6) months. In dusty and/or high use areas, it's recommended to change the filter every three (3) months.
Part no. BD988SF

GEL Blocks-

We recommend that the blocks are replaced every month
Part no. HDC-BIO GELS TUB 12B

11. SUPER FILTER ASSEMBLY INFORMATION

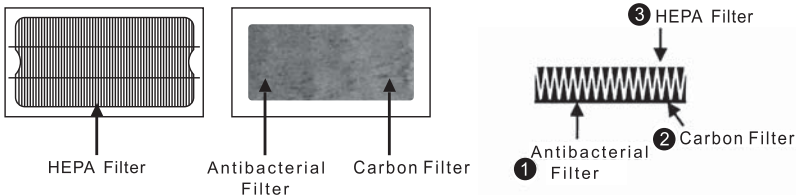

12. INSTRUCTIONS FOR USE, MAINTENANCE AND CHANGING THE ABSORBENT CERAMIC PLATE

Under normal conditions the ceramic plate absorbs excess water blown from the hands, which then evaporates, in a continuous cycle. The ceramic plate can absorb 70g of water, and has the capacity to take a full load approximately 280 times per day.

Maintenance simply requires cleaning its surface. Normally, its lifetime will be the same as the machine. Improper use or maintenance could result in breakage; see below for replacement instructions.

1. Use the L key to loosen the security screw and remove the drawer (fig.1)
2. Use the L key to loosen the security screw of the base plate and remove the machine (fig.2)
3. Use a screwdriver to loosen the screw (2 pcs) on the ceramic, and replace it with a new one. (fig. 3)
4. Re-install and secure the security screw of the base plate.
5. Re-install the draw and lock with the security screw.

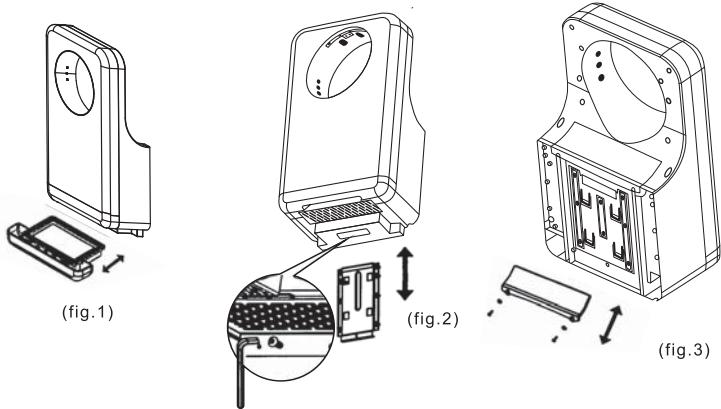

13. DRAIN TANK INSTRUCTIONS

Generally, the excess water blown from the hands will evaporate in the absorbent ceramic. During high traffic times, excess water will flow to the drain tank automatically. The capacity of the drain tray is 240 cc. It's recommended to clean the drain tank regularly. If the drain tank is full water will come through the "overflow hole". A drainpipe (not included) can be added if necessary. The specifications of the drainpipe is I.D. 6mm (15/64"), O.D. 10mm (25/64") (fig.1)

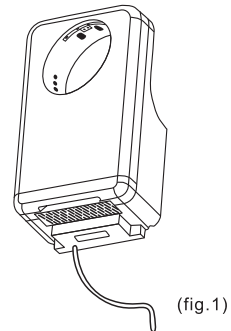

14. REPAIR PARTS LIST

KEY	PART NO.	DESCRIPTION
1	BD001P	Ceramic absorber
2	BD002P	Wall bracket
3	BD003P	Backplate
4	BD004P	Back cover
5	BD005P	Cable gland
6	BD006P	Terminal block
7	BD007P	Switch cover
8	BD008P	Water reservoir
9	BD009P	PCB
10	BD0010P	Switch cover
11	BD0011P	Motor
12	BD0012P	Cover
13	BD0013P	Filter rubber
14	BD0014P	HEPA
15	BD0015P	Drawer assembly
16	BD0016P	Motorframe
17	BD0017P	Motor cover

15. DIAGRAM

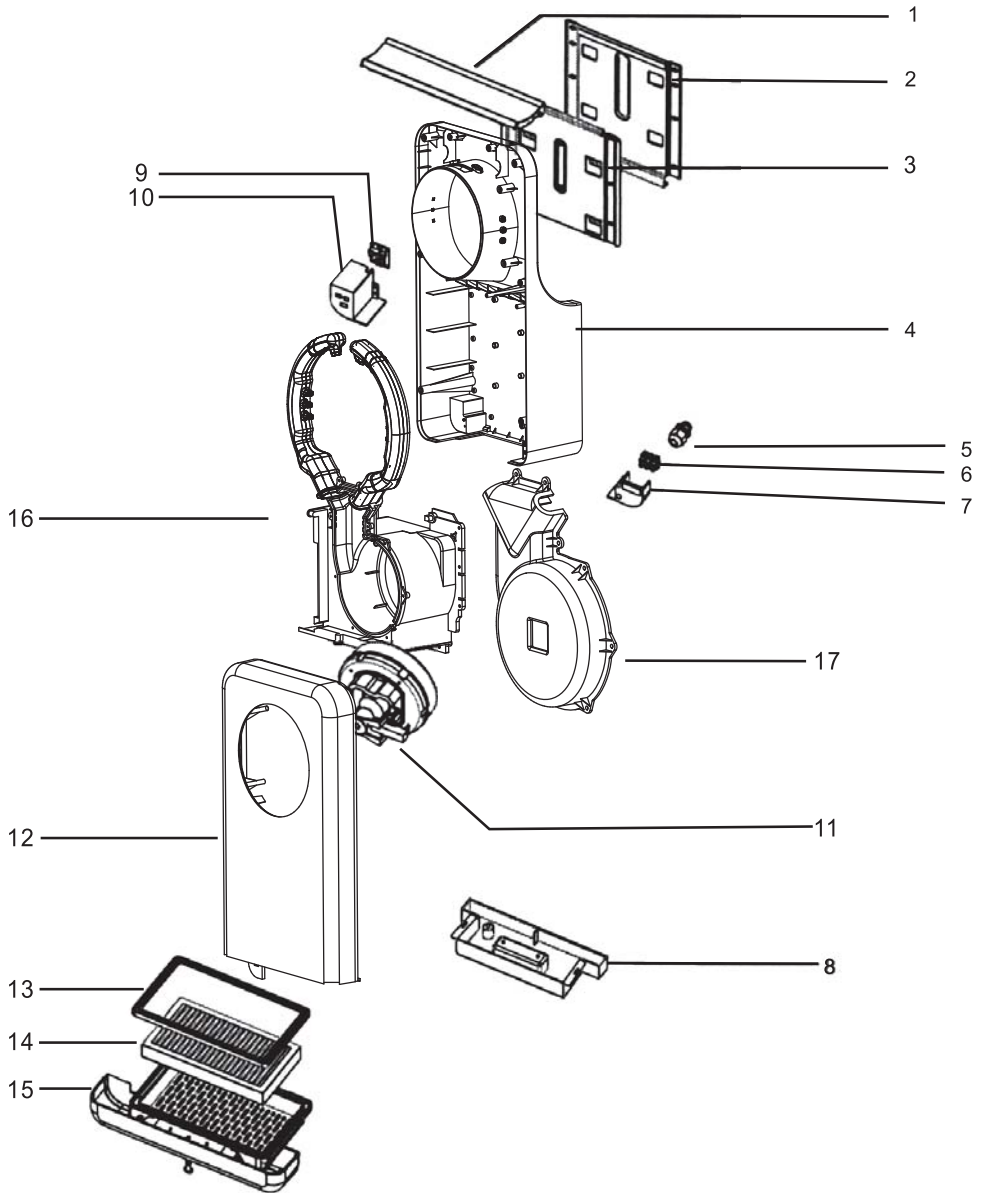

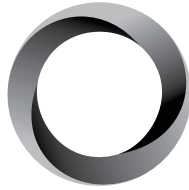

BLUEDRY